

Emergency Showers and Eyewashes



www.worksafesask.ca

WorkSafe[™]
SASKATCHEWAN

Work to live.

Table of contents

Introduction	2
What are the requirements of the legislation?	2
Regular showers.....	2
Emergency showers and eyewashes	2
General requirements	3
Where are emergency showers and eyewashes required?.....	4
Corrosive substances.....	4
Other harmful substances.....	5
Regular basis	5
Manner of use	5
What are “approved” emergency showers and eyewashes?	6
Acceptable emergency showers	6
Acceptable eyewashes.....	7
Personal eyewash equipment.....	7
Drench hoses	8
Illustrations.....	9
Illustration 1: Plumbed eyewash.....	9
Illustration 2: Non-pressurized self-contained eyewash	10
Illustration 3: Pressurized self-contained eyewash	10
Illustration 4: Typical eyewash gauge	11
Illustration 5: Eye/face wash.....	11
Illustration 6: Combination unit	12
Illustration 7: Personal wash units	13
Illustration 8: Drench hose	13
Illustration 9: Drench hose with eyewash attachment	13

Please note

This publication is not designed to interpret the legislation. It is not intended to be used in court. Please use the original legislation whenever you wish to interpret or apply the law.

To purchase copies of *The Saskatchewan Employment Act* or *The Occupational Health and Safety Regulations, 1996* contact Publications Saskatchewan in Regina at:

Phone: 306.787.6894 Fax: 306.798.0835

Industries under federal jurisdiction, such as transportation, broadcasting and telecommunications, are governed by *The Canada Labour Code*. If you work for a federally regulated industry, please contact the appropriate agency for information.

Introduction

This publication will help you to:

- Determine if your workplace requires regular or emergency showers or eyewashes under the legislation.
- Learn the standards for emergency showers and eyewashes.

What are the requirements of the legislation?

In Saskatchewan, *The Occupational Health and Safety Regulations, 1996* require:

- **Regular showers** in the workplace where workers' skin is regularly exposed to harmful or offensive substances (see regulation 74).
- **Emergency showers** where workers could be quickly injured after substantial skin contamination by corrosive or other harmful substances (see regulation 312).
- **Eyewashes** where workers' eyes could be quickly injured by corrosive or other harmful substances (see regulation 313).

Some workplaces may require both regular and emergency showers.

Regular showers

Working conditions may result in workers' skin being routinely exposed to substances to an extent that is harmful or offensive. In these situations, employers are required to provide suitable and adequate regular shower facilities. A regular shower is intended to prevent harmful effects that can occur after repeated exposures (cumulative or chronic effects) to certain substances or to wash off offensive substances.

Employers must allow sufficient time during normal working hours for workers to use these facilities. The facilities must include suitable and clean change facilities.

Emergency showers and eyewashes

Accidents and other unanticipated events may expose workers to corrosive or other harmful substances that can injure exposed skin or eyes after a single exposure. Often the injury occurs immediately or within a short time (such as chemical burns). Some substances can be rapidly absorbed and have toxic effects within a short time (such as quick-acting poisons).

Where these effects can occur after a worker or worker's clothing is substantially contaminated by corrosive or other harmful substances, the employer must provide and maintain "an approved means of bathing or showering the worker with lukewarm water".

Where eye injury can occur from exposure to corrosive or other harmful substances, the employer must provide "approved equipment to flush the eyes".

General requirements

- The employer, in consultation with the occupational health committee, the worker occupational health and safety representative, or the workers, should examine the need for an emergency shower and/or eyewash based on this guideline.
- Emergency showers and eyewashes that meet the performance specifications described in this guideline are acceptable as “approved” emergency showers and eyewashes. Eyewash/shower combination units can be used as long as the shower and eyewash components both meet the corresponding performance specifications.
- The shower and eyewash units must be readily accessible and must effectively and promptly remove the harmful substance.
- Audible alarms or blinking lights may be used to indicate when emergency equipment is in use. Alarms that can immediately alert other workers are particularly important where workers may require the use of emergency showers and eyewashes in remote or isolated areas.
- Employers must ensure that all plumbed in units are flushed weekly and must ensure their proper operation and drainage. Self-contained units must be visually inspected weekly to see if the flushing fluid needs replacing.
- The employer must provide instruction to workers on how to properly use emergency showers and eyewashes.
- Plumbed in and self-contained units shall be protected from freezing and must be inspected annually to assure conformation to the ANSI Z358.1-2014 standard.
- Workplaces with the following activities will likely require an emergency shower and/or eyewash:
 - petroleum well servicing
 - electroplating
 - chemical formulation
 - metal cleaning
 - metal melting and moulding
 - battery servicing
 - gold extraction
 - pesticide formulation
 - hydrofluoric acid use (etchers and formulators)
 - caustic use in container cleaning
 - penta wood treatment
 - laundry services
 - water treatment plants
 - anhydrous ammonia sales
 - chemical laboratories

Where are emergency showers and eyewashes required?

An emergency shower is required where workers handle:

- Large quantities (litres)¹, of corrosive or other harmful substances that have rapid effects, on a regular basis, in a manner of use that may result in substantial contamination of the worker's skin.

An eyewash is required where workers handle:

- Substances that are corrosive or otherwise harmful to eyes, on a regular basis, in a manner of use that may result in harmful eye exposure.

However, in some cases emergency showers and eyewashes are needed when the substance or a container of the substance is always present at the worksite, but not necessarily handled as part of the normal work processes. An example is when a substance is used only during maintenance.

Corrosive substances

Corrosive substances include acids, bases, anhydrides, peroxides and some metal salts. Strong oxidizing agents are often corrosive. The skin and eye corrosion hazard of acids and bases depends on:

1. The pH (or relative acidity or basicity) of a solution containing the substance. (There is more risk of injury as the pH becomes lower than 2.5 or higher than 11.5).
2. The nature of the substance.
 - Bases (such as caustic soda) are more harmful than acids because they dissolve tissues and penetrate deeper into the skin.
 - Mineral acids (such as hydrochloric acid or nitric acid) are generally more harmful than organic acids (such as acetic or citric acid).
 - Some substances like hydrofluoric acid, chromic acid, phenol and chlorinated acids are exceptionally corrosive.
3. The concentration of the substance.
 - An acute corrosion hazard should be suspected when the concentration of one of these substances exceeds 20 per cent. There are some exceptions, including highly corrosive substances like hydrofluoric acid, where concentrations less than 10 per cent can be severely corrosive.
 - The eyes are more sensitive to the effects of corrosive substances. Even low concentrations of corrosive substances should be suspected as being harmful to the eyes.

¹Lesser volumes of a small number of very harmful substances like hydrofluoric acid can cause severe and even lethal effects when only small areas of skin are contaminated.

Other harmful substances

A substance that has a dermal LD50 value of less than 200 mg/kg (very toxic) can cause a toxic effect when applied to the skin for a short time². Certain insecticides, wood preservatives and organic metal compounds are examples of such toxins.

Strong allergenic agents, such as plastic monomers (for example, TDI) can cause severe allergic or irritant effects after brief skin exposures.

Particles can cause mechanical injury to the eye. In addition, some may have toxic effects or cause eye infections. Metallic or crystalline particles can be especially harmful.

Substances identified on Safety Data Sheets (SDS) as severe skin or eye irritants and any other substance for which the SDS indicates an emergency shower or an eyewash as a first aid recommendation should be considered.

However, the risk of injury must be the prime factor for determining whether an emergency shower or eyewash is needed.

Regular basis

Regular basis means that the substance is used repetitively, as part of the normal work processes.

Manner of use

The way a product is used affects the risk of eye exposure or substantial contamination of the worker's body.

Handling large quantities or working with or near open containers or tanks of substances is more likely to result in accidents that substantially contaminate a worker.

The height at which a substance is stored or handled is an important factor. If the height is above shoulder level, the risk of an accidental exposure is greater. This is especially true if the substance is being transferred from one container to another above shoulder height.

Eye contact is more likely when the substance becomes airborne in adequate concentrations or amounts (for example, in the form of particles, mists or vapours) or when the substance splashes during work processes.

Consider the extent of containment of the substance, the likelihood of accidental releases, the availability and use of protective clothing or equipment and the level of worker training.

² A dermal LD50 value of less than 200 mg/kg means that when doses (of less than 200 mg of the substance per kg of each test animal's body weight) were applied to the test animals' skins, 50 per cent of the animals died.

What are “approved” emergency showers and eyewashes?

At present, the standard for emergency showers and eyewashes is The American National Standards Institute (ANSI) Standard for Emergency Eyewash and Shower Equipment (publication Z358.1-2014). Equipment that meets the existing ANSI standard or any updated standard will likely meet the performance specifications described below.

To order the standard, which also includes information on installation and testing, phone the American National Standards Institute Customer Service at 1.212.642.4980.

Acceptable emergency showers

See illustration 1, (page 9) for the recommended dimensions for emergency showers. Both self-contained and plumbed units may comply with the ANSI standard.

Performance standards include the following key points:

1. The shower must be constructed of non-corrosive materials.
2. Water must be delivered at a velocity that is not injurious to workers for 15 minutes. The shower must deliver at least 75.7 L/min (20 gal/min) for plumbed or self-contained units.
3. The on/off control must be easy to reach and start the water flowing within one second or less of being activated.
4. The valve must remain open and the flow rate maintained without the use of the operator’s hands, until intentionally shut off.
5. There must be a minimum unobstructed area of 86.4 cm (34 in) in diameter if an enclosure is used.
6. The emergency shower must be identified with a clearly visible sign and the area around it shall be well-lit.
7. The shower must be readily accessible, meaning an injured worker anywhere in the risk area must be able to reach the nearest shower within 10 seconds. The path to the shower must be kept clear.
8. Should be within 30 metres (100 feet) of the risk area.

The water temperature should be kept constant and should be between 16 and 38°C. In situations where the chemical may burn the skin, the temperature should be closer to 15°C. In rare situations certain chemicals may undergo injurious reactions that are accelerated at certain temperatures. Consult the SDS, and the chemical supplier for any restrictions on temperatures used for emergency showers.

Regular showers can often be modified to meet these standards.

Acceptable eyewashes

Both self-contained and plumbed units meet the existing ANSI standard. See illustration 2 for recommended dimensions for emergency eyewashes, and some examples of acceptable eyewashes.

Performance standards include the following key points:

- The water velocity must be low enough not to be injurious to the user. Water must be delivered to both eyes simultaneously, at a rate of at least 1.5 L/min (0.4 gal/min) for 15 minutes. If it is eye/facewash equipment, it must deliver a minimum of 11.4 L/min. (three gal/min) for 15 min.
- The eyewash must be constructed of non-corrosive materials.
- Water flow must start within one second of being turned on and should remain on, without the use of the operator's hands, until intentionally shut off.
- The water must be clean and without visible contamination (dirt, rust, etc.) and not acidic or alkaline.
- If self-contained units are used, water must be replaced and/or treated according to the manufacturer's instructions. In the absence of manufacturer's instructions, water should be changed monthly.
- Another appropriate liquid is acceptable, if the supplier indicates the liquid is for use as an eyewash.
- The eyewash must be readily accessible, meaning an injured worker anywhere in the risk area must be able to reach it within 10 seconds. The path to the eyewash must be kept clear.

The water temperature should be kept constant between temperatures of 16 and 38°C. Temperatures above 27°C are advised in most cases. In situations where the chemical can burn, temperatures closer to 15°C are recommended. In rare situations, certain chemicals may undergo injurious reactions that are accelerated at certain temperatures. Consult the SDS and the chemical supplier for any restrictions on temperatures used to flush the eyes.

Some faucet-mounted eyewashes meet the ANSI standard. Determine from the manufacturer whether a unit has been tested and whether it met the ANSI standard. The valve control should be adjusted to divert the water supply from the faucet to the eyewash. Ensure the correct flow and temperature of the flushing water by adjusting the taps. Post a sign or otherwise ensure that the tap and valve positions are maintained.

Personal eyewash equipment

Personal eyewash equipment (bottles) are inadequate when used alone, but can be used to support emergency eyewashes. The value of these units is that they can be kept in the immediate area of the worker and used immediately following an exposure. The worker can then proceed to the emergency eyewash and flush for the 15-minute period. Because they do not provide 15 minutes of continual flushing, they do not meet the standards for emergency eyewashes when used alone. Personal eyewash equipment is not a substitute for a 15-minute emergency eyewash, except in rare situations where the use of the latter is not practicable.

Instructions and the expiry date must be permanently affixed to the bottles, and the bottles should not be exposed to ambient temperatures exceeding 38°C to protect from freezing.

Drench hoses

Drench hoses can be used to support self-contained or plumbed shower or eyewash units, but cannot replace them. Drench hoses used with truck-mounted reservoirs may replace showers for temporary worksites where the risk of accidental, substantial contamination is low.

Illustrations

Illustration 1: Plumbed eyewash

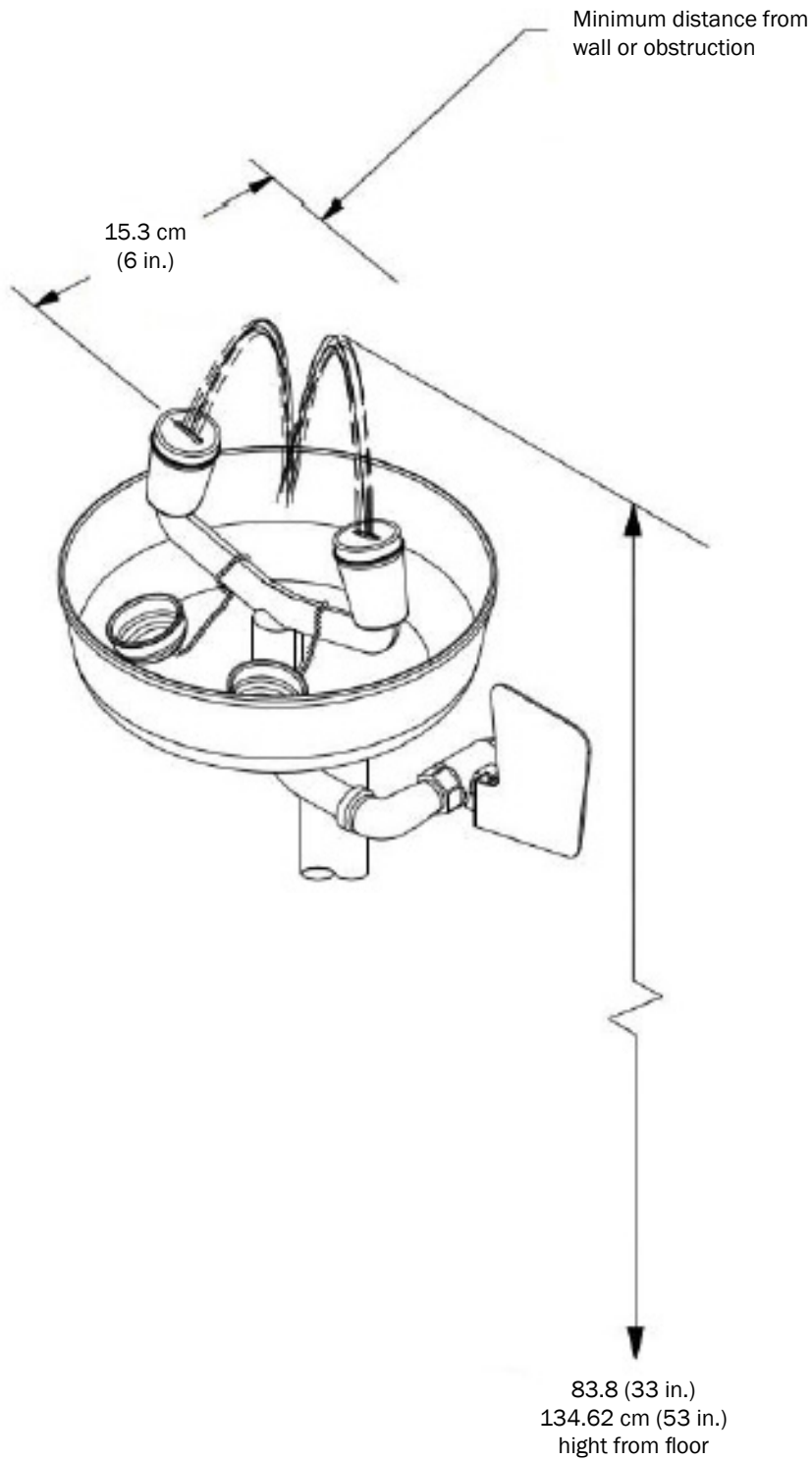

Illustration 2: Non-pressurized self-contained eyewash

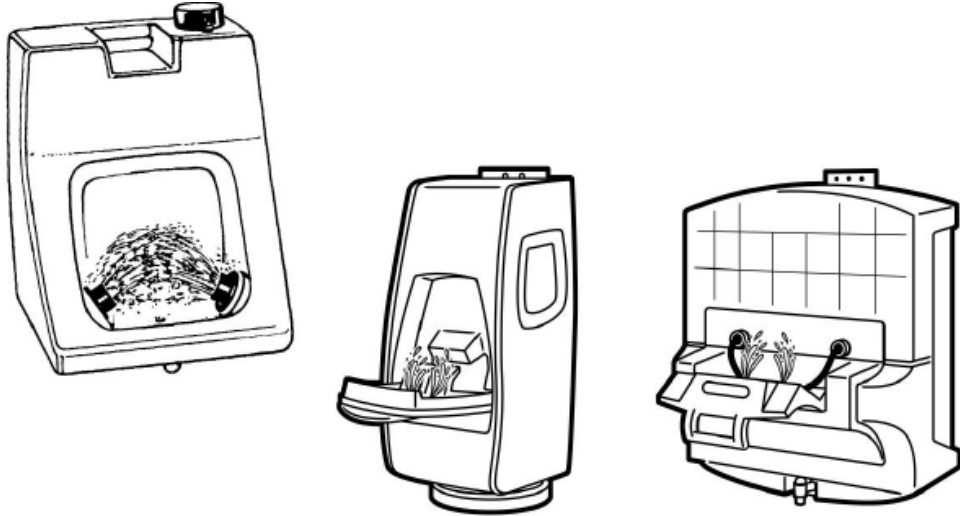

Illustration 3: Pressurized self-contained eyewash

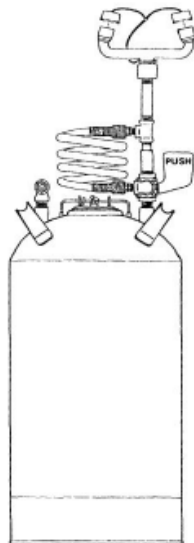

Illustration 4: Typical eyewash gauge

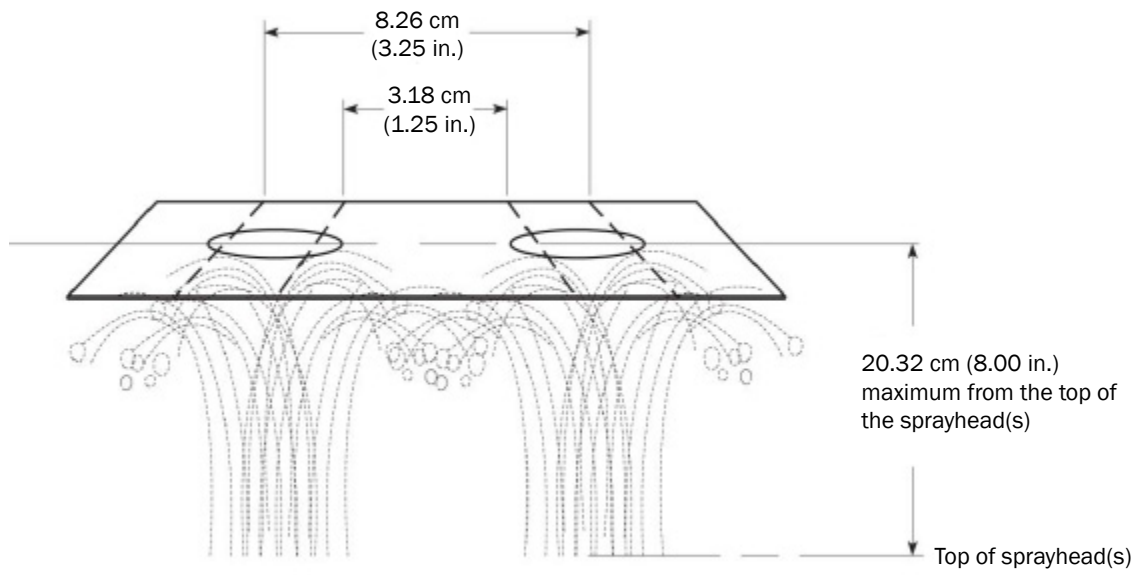

Illustration 5: Eye/face wash

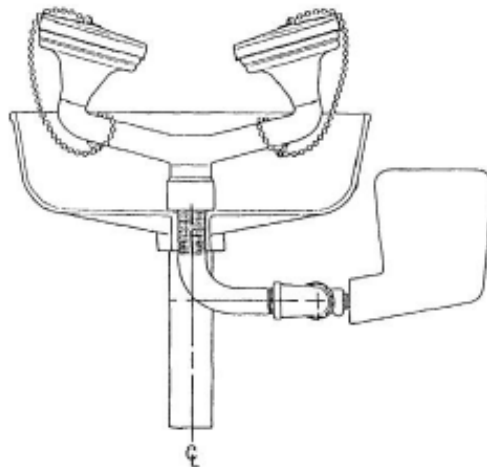

Illustration 6: Combination unit

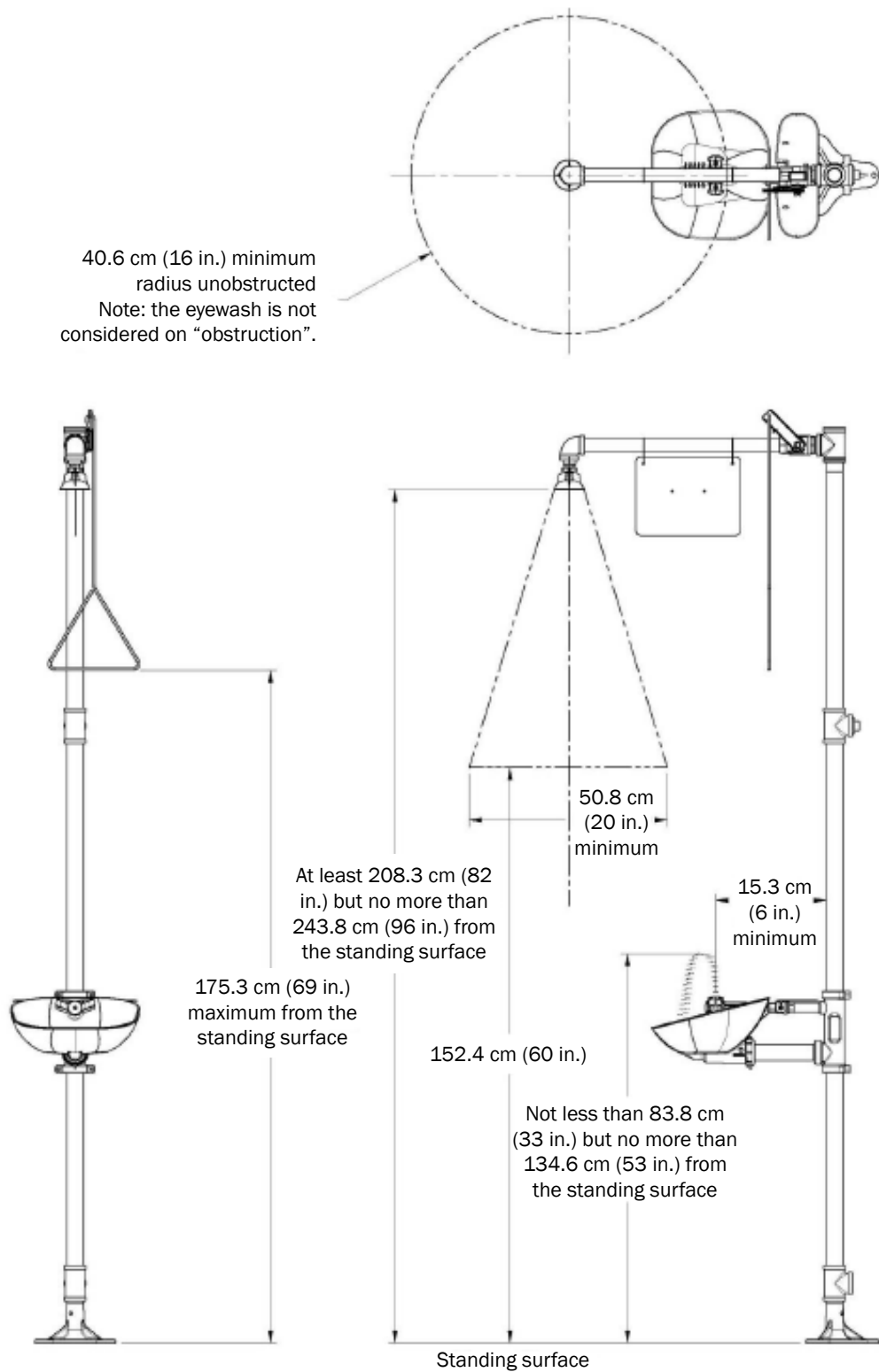

Illustration 7: Personal wash units

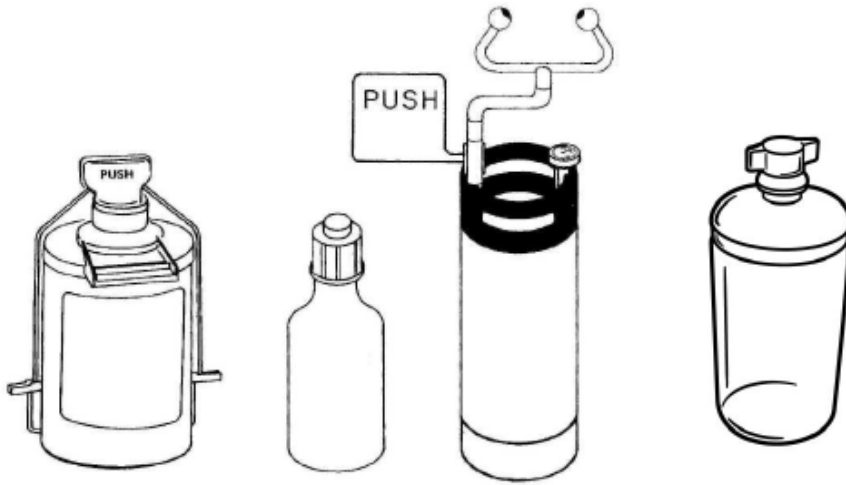

Illustration 8: Drench hose

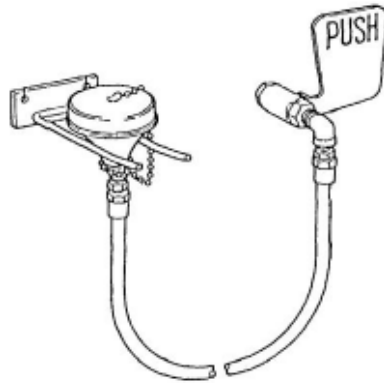

Illustration 9: Drench hose with eyewash attachment



WorkSafe Saskatchewan
Head Office
200 - 1881 Scarth Street
Regina SK S4P 4L1

Saskatoon Office
115 24th Street East
Saskatoon SK S7K 1L5

Phone 306.787.4370
Toll free 1.800.667.7590
Fax 306.787.4311
Toll-free fax 1.888.844.7773

Online www.worksafesask.ca

